

EV CONVERSION OPTIONS

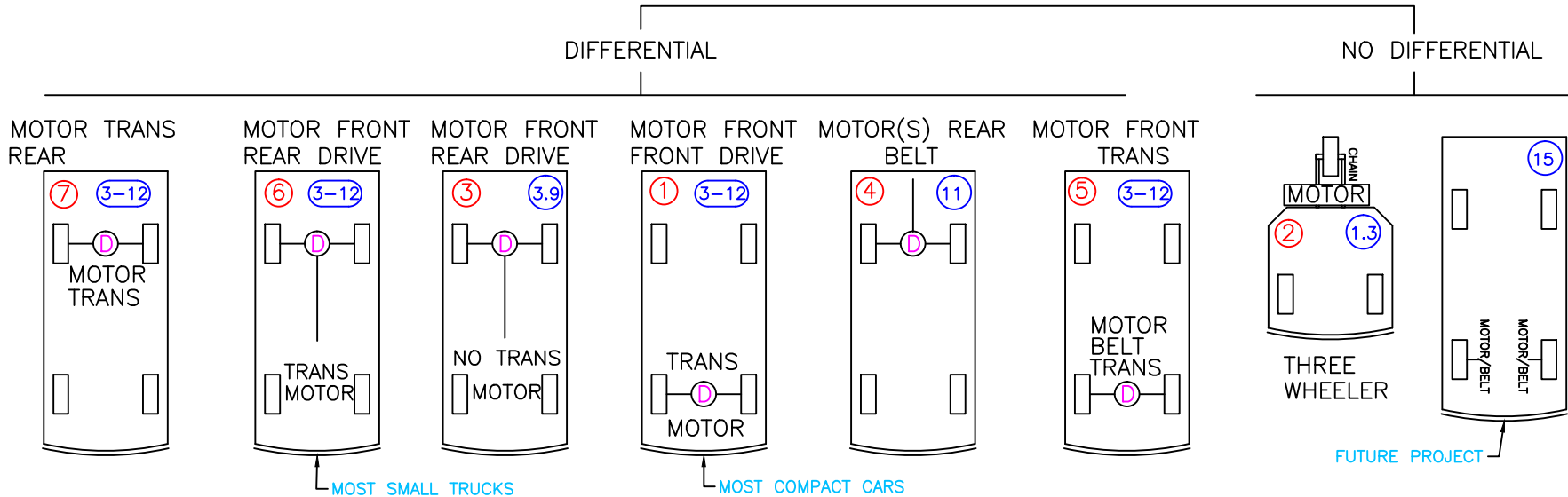

GENERALITIES:

1. AC MOTORS SPIN AT HIGHER RPMS, ARE MORE EFFICIENT, MORE \$.
2. THE CLUTCH CAN BE OMITTED.
3. NEED GEARING, IN ADDITION TO THAT IN A DIFFERENTIAL.
4. TRANSMISSIONS ARE NOT 100% EFFICIENT. IE HEAT
5. MORE WEIGHT / MORE BATTERIES
6. MAJORITY OF DIY CONVERSIONS ARE TYPE 1 OR 6

LEAST EXPENSIVE CONVERSION- 4/5K\$

1. MOTOR CONNECTED TO DRIVESHAFT
2. DC MOTOR
3. RECYCLED DATA CENTER BATTERIES
4. MAY SACRIFICE ACCELERATION OR TOP SPEED.

X-X

DENOTES OVERALL RATIO RANGE

EXAMPLES: SEE COLOR CODING IN BOX

1. D.M -HAMPTON-<http://www.evalbum.com/2619>
2. D.C.S -DAVID CROWE
3. D.N -KEN SHELDON
4. A.S -SWANN-<http://www.evalbum.com/1312>
5. A.T.C.L.M -DOUGLASS-<http://www.evalbum.com/2680>
6. D.M -KOBBER-<http://www.evalbum.com/1280>
7. A.M -SCHRAMM-<http://www.evalbum.com/2475>

